

# Technical data sheet

PSI AUDIO

A25-M

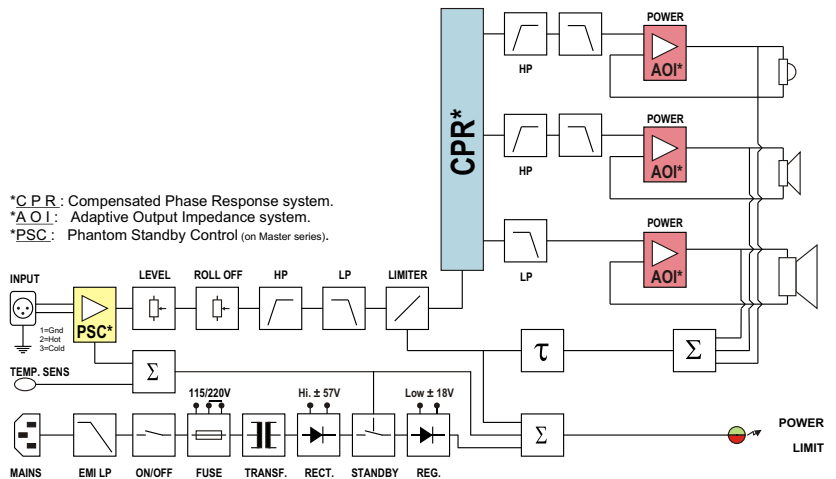
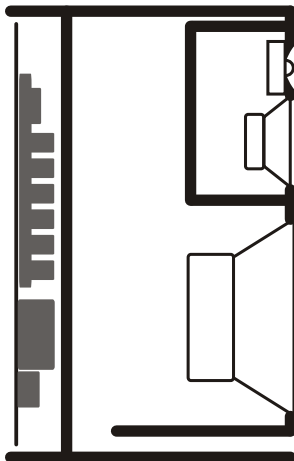

\*C.P.R. : Compensated Phase Response system.  
\*A.O.I. : Adaptive Output Impedance system.  
\*P.S.C. : Phantom Standby Control (on Master series).

- Puissance RMS Power RMS **170+80+50 W**
- Puissance programme Program power **300 W**
- Impédance d'entrée Input Impedance **Sym, 10k Ohms**
- Sensibilité pour 100 dB @ 1m Sensivity for 100 dB @ 1m **0.775 V**
- Rapport signal sur Bruit Signal to Noise Ratio **-96 dBA**
- Saturation d'entrée Input Overload **24 Vpp**
- Niveau max. continu, 1m Continuous Max SPL, 1m **110 dB (single)**
- Niveau max. programme, 1m Program Max SPL, 1m **121 dB (pair)**
- Réponse à -6 dB Response at -6dB **32 - 23000 Hz**
- Tolérances Tolerances **±1.5 dB (38Hz - 20kHz)**
- Distorsions THD Distortion THD **< 1% (70Hz-20kHz)**
- Phase tolérances Phase tolerances **±45° (150Hz - 20kHz)**
- Dispersion (B.R. 4 - 16 kHz) à -6 dB Dispersion (P.N. 4 - 16 kHz) at -6 dB **90° x 80° (H x V)**
- Système System **3 Way(s)**
- Fréquence de coupure Crossover frequency **580Hz, 3.1kHz**
- Dim. basses Ext. / Membrane Woofer's dim. Ext. / Diaphragm **Ø 258 mm / Ø 210 mm**
- Dim. mediums Ext. / Membrane Medium's dim. Ext. / Diaphragm **Ø 142 mm / Ø 102 mm**
- Dim. aiguës Ext. / Membrane Tweeter's dim. Ext. / Diaphragm **Ø 100 mm / Ø 25 mm**
- Connecteurs Connectors **1 x XLR F / 3P**
- Signal entrée Signal input **1=GND, 2=(+), 3=(-)**
- Matériaux du boîtier Box Material **MDF**
- Dimensions boîtier L x H x P mm **320 x 590 x 380**
- Dimensions cabinet W x H x D mm **320 x 590 x 380**
- Poids brut / net Gross / Net Weight **32.1 / 28.4 Kg**
- Tension de secteur Voltage **115/230V (50-60Hz)**
- Consommation Consumption Standby-Quiescent-Max **1.8 - 8 - 200 VA**
- Humidité Moy / Max Mean / Max Humidity **< 75% / < 90%**
- Température externe External Temperature **5 - 40 °C**

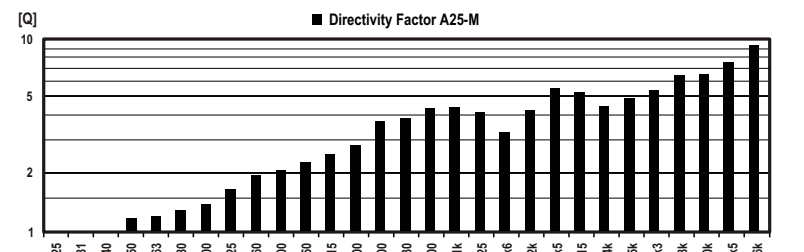
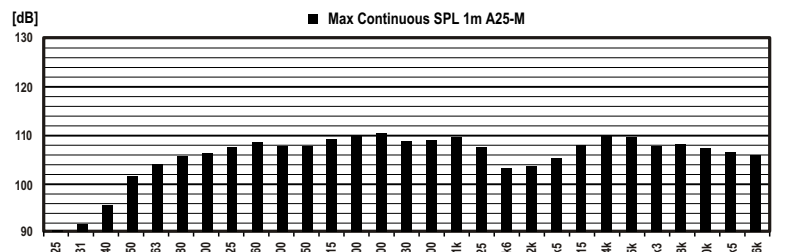
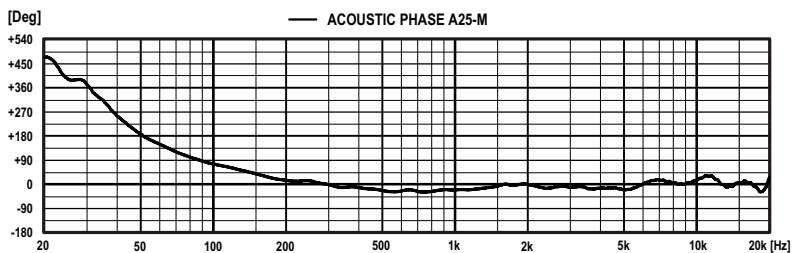
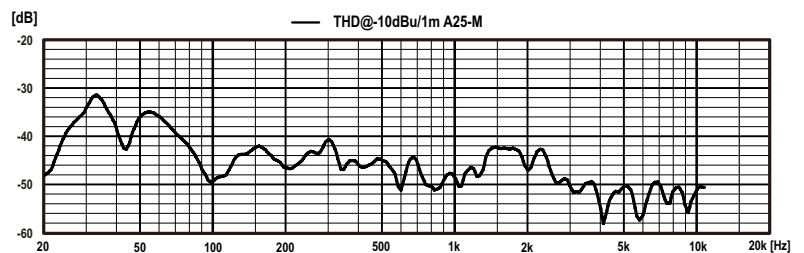
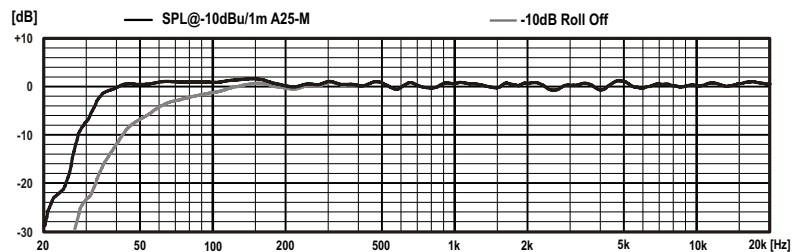

All dimensions are in mm

## Mounting

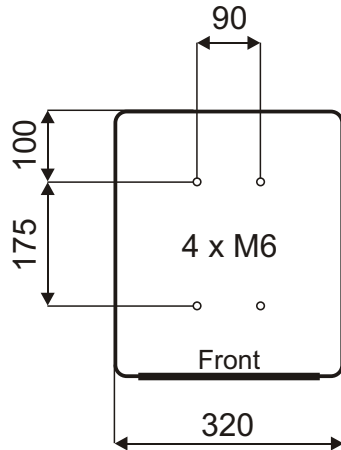

Bottom view

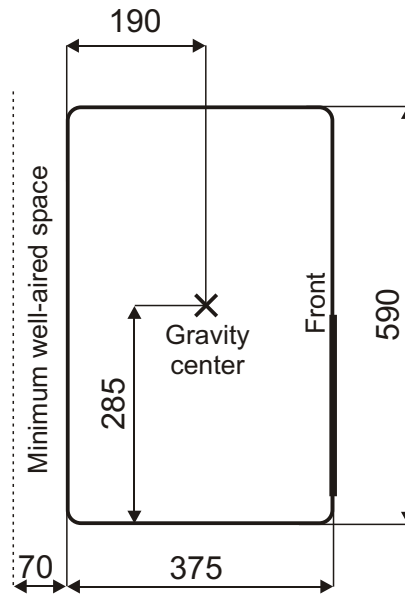

Side view

see our website for more information about installation

## Acoustical axis

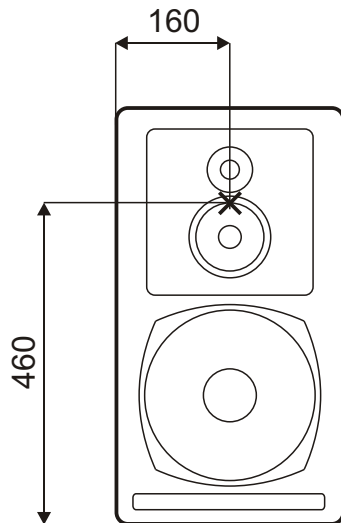

Front view

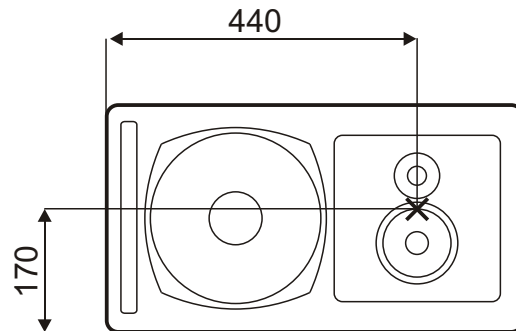

## Mid/High baffle orientation

As mentioned on the drawing here above, you can change the orientation of the mid/high baffle. Before this change, the power cable must not be connected. Be sure that this operation does not cause any short-circuit to the connections of the baffle.

**Measurement environment:** Large anechoical room  
 Temperature  $23 \pm 2^\circ\text{C}$   
 Humidity  $50 \pm 20\%$